

# Switches

## Disconnectors



## LTMP line

### Applications

Traction circuit configuration change  
in multi-system locos

Isolation of power converter

Isolation of traction motors

Modular multipole-multiposition off-load disconnectors.

The disconnectors are configurable assembling side by side poles, every one completely independent and controlled by a motor.

The modular structure allows easy maintenance through independent replaceability of every single pole. Feedbacks may be managed, on demand, through a low voltage connector installed on every pole.

Reference standard IEC 60077-2.



*Microelettrica Scientifica*

# Switches

## Disconnectors: LTMP Line

### Main Features of each Pole:

- 2 versions: 1000 or 2000A thermal current
- 3 configurations: NO or NO+NC or CO
- Fully modular construction
- Electric motor actuated

### Technical Data

Rated Max Voltage (U <sub>max</sub> )	4000V <sub>DC/AC</sub>
Rated Operational Current (I <sub>e</sub> ) at 75°C	Up to 2000A
Auxiliary Contacts (type SAIA-BURGESS)	2 CO per pole

### Overall dimensions (mm)

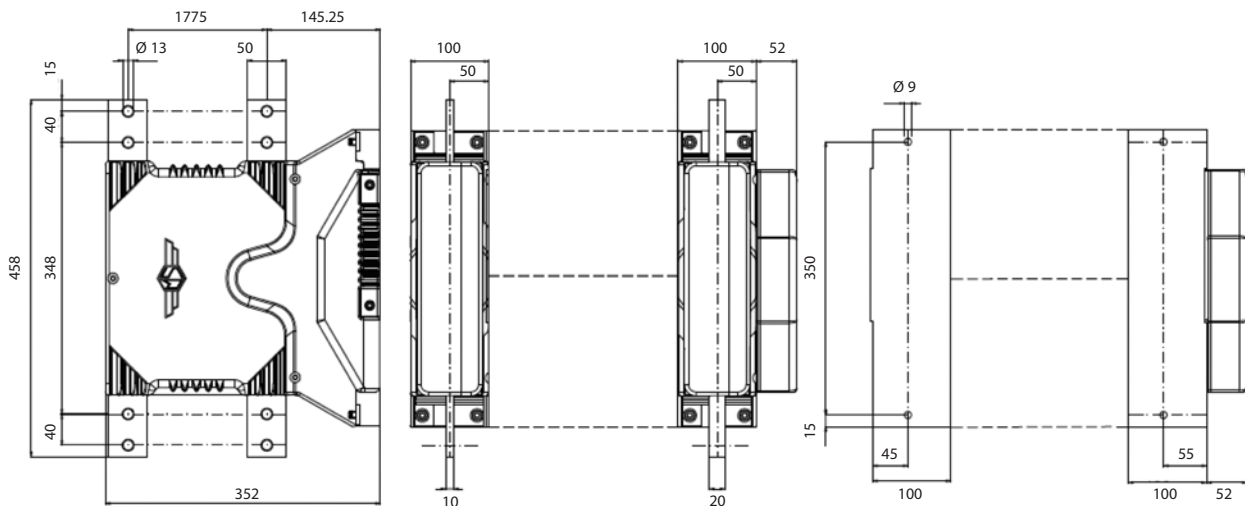

### Pole Configuration

NO Pole

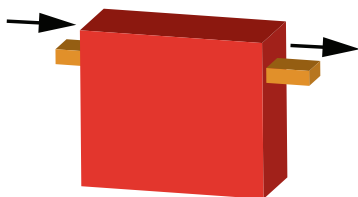
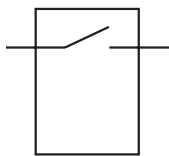

NO-NC Pole

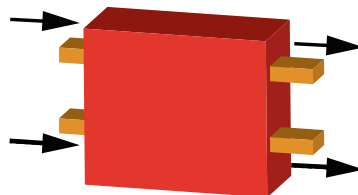
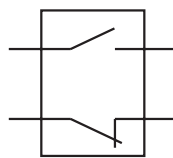

CO Pole

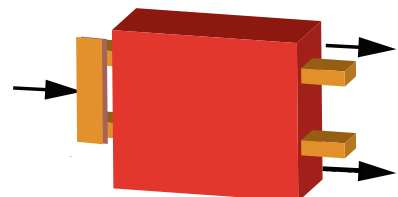
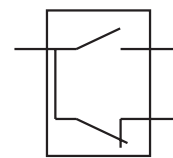

**KNORR-BREMSE**



*Microelettrica Scientifica*